

# CSM/DCM Series

多色/多料臥式系列

## 'Multi-colour' or 'Multi-component' Horizontal Series

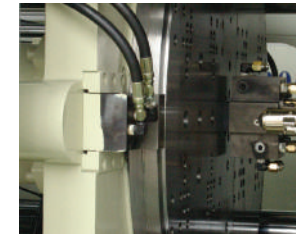

高精密度的轉盤結構  
High accuracy rotary index table

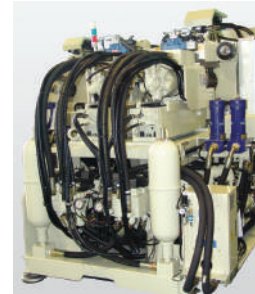

ACC高速射出儲能裝置及全閉環油電迴路  
Accumulator for high speed injection, and injection closed-loop system

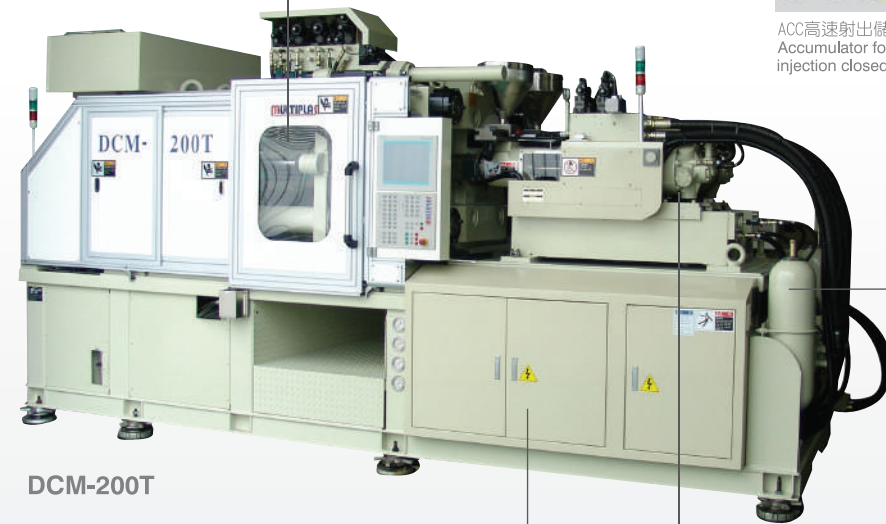

DCM-200T



精密電控系統  
Advanced control system



優良之塑化單元  
Outstanding plasticizing unit



CSM-200T-3C

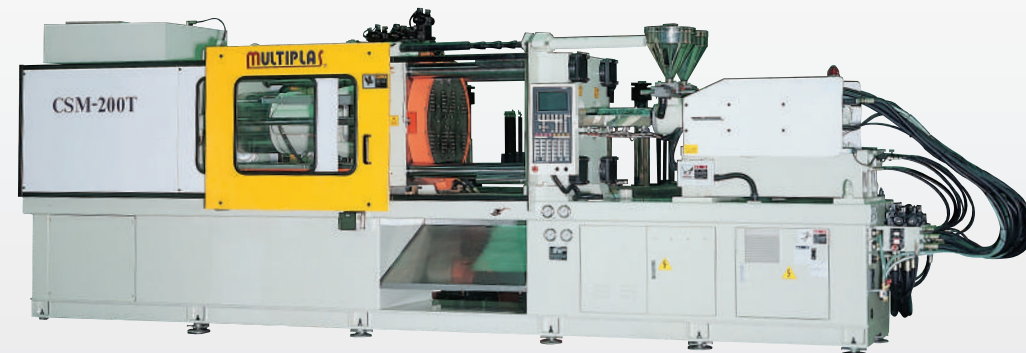

CSM-200T

### 雙/三色(料)機的射座配置模式 Injection Unit Configuration for 2/3-color (component) machines

#### 雙色 2 - color

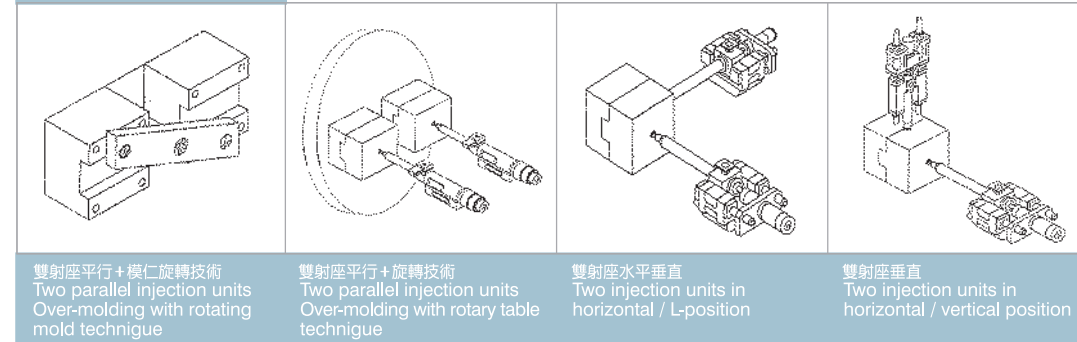

雙射座平行 + 橫/垂直  
Two parallel injection units Over-molding with horizontal / vertical position

雙射座平行 + 旋轉技術  
Two parallel injection units Over-molding with rotary table technique

雙射座水平垂直  
Two injection units in horizontal / L-position

雙射座垂直  
Two injection units in horizontal / vertical position

#### 三色 3 - color

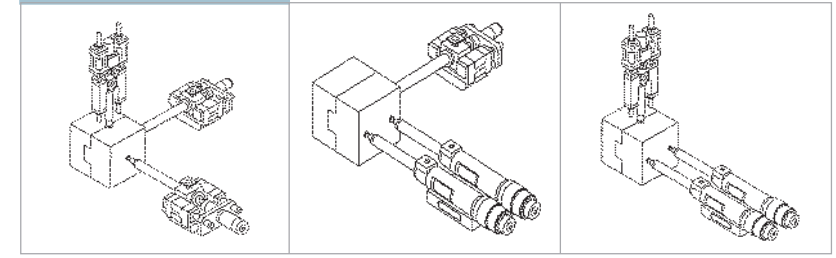

### 規格 Specifications

射出裝置選項 INJECTION UNIT OPTION		單位 UNIT	A			B			C			D			E			F			G			H		
射出裝置 INJECTION UNIT	螺桿直徑 Screw diameter	mm	Ø18	Ø22	Ø25	Ø22	Ø25	Ø30	Ø25	Ø30	Ø35	Ø30	Ø35	Ø40	Ø35	Ø40	Ø45	Ø40	Ø45	Ø50	Ø45	Ø50	Ø55	Ø50	Ø55	Ø60
	理論射出容量 Theoretical injection volume	cm <sup>3</sup>	25	38	49	45	58	84	68	98	134	113	154	201	173	226	286	276	350	432	350	432	522	471	570	678
	射出重量 Injection capacity(PS)	g	23	35	45	41	52	76	62	89	122	103	140	183	157	205	260	262	332	410	332	410	496	447	541	644
	射出壓力 Injection pressure	kg/cm <sup>2</sup>	3038	2033	1575	2612	2033	1404	2800	1944	1428	2800	2057	1574	2603	1993	1574	2460	1944	1575	2497	2023	1672	2527	2088	1754
	射出速率 Injection rate	cm <sup>3</sup> /s	36	54	70	42	55	79	56	81	110	78	106	138	98	128	162	128	162	200	182	226	273	203	246	292
	可塑化能力 Plasticizing capacity(PS)	kg/h	14	23	32	15	21	33	23	35	54	32	49	69	43	60	83	50	69	92	75	100	128	90	115	144
	螺桿轉速 Screw rotation speed	rpm	10-375			10-253			10-270			10-249			10-218			10-180			10-195			10-176		
	電熱容量 Heating capacity	kW	3			3.5			5.1			6.9			7.5			8.1			11			13		
	需求壓力 Required driving power	hp (kW)	10(7.5)			10(7.5)			15(11.2)			20(15)			25(18.7)			30(22.5)			40(30)			50(37.5)		

型號 MODEL	單位 UNIT	CSM-120T		CSM-150T		CSM-200T		CSM-250T		CSM-300T		CSM-430T		CSM-550T	
		射出裝置選項 INJECTION UNIT OPTION		序號 SERIES NO.		序號 SERIES NO.		序號 SERIES NO.		序號 SERIES NO.		序號 SERIES NO.		序號 SERIES NO.	
鎖模裝置 CLAMPING UNIT	鎖模力 Clamping force	120		150		200		250		300		430		550	
	最小模厚 Minimum mold height	180		200		220		220		260		280		350	
	開模行程 Opening stroke	460		580		700		780		850		950		1050	
	最大開距 Maximum daylight	640		780		920		1000		1110		1230		1400	
	柱內間距 Distance between tie bars(HxV)	410x410		460x460		520x520		560x560		650x650		750x750		850x850	
	模板尺寸 Platen size(HxV)	590x590		690x690		770x770		840x840		970x970		1090x1090		1240x1240	
	轉盤直徑 Rotary table diameter	Ø530		Ø610		Ø700		Ø740		Ø880		Ø1020		Ø1120	
	成品頂出距離 Ejector stroke	120		150		150		180		180		200		200	
	頂出力 Ejector force	4.9		4.9		5.8		7.7		7.7		12.5		12.5	
	電動馬達 Electric power	25(18.7)		30(22.5)		40(30)		50(37.5)		60(45)		80(60)		100(75)	
其他 OTHERS	油箱容量 Oil tank capacity	290		400		540		640		820		930		1140	
	機械尺寸 Machine dimensions(LxWxH)	4.4x1.2x1.9		5.0x1.3x2.1		5.5x1.4x2.1		5.8x1.4x2.3		6.3x1.6x2.4		7.1x1.7x2.6		7.8x1.9x2.8	
	機械重量 Machine weight	5.7		7.8		10.5		12.2		14.5		18.8		25	

為配合設計的改進與更新，以上規格如有更改，恕不另行通知。  
Due to continuous development of our products, specifications are subject to change without prior notice.

本公司亦接受特殊規格之訂製，歡迎垂詢。  
Machine can be custom made upon request. Please call for further details.